

HI·MACS

The shape of your ideas

HIMACS for facades

Solid Surface Material

HIMACS. The shape of your ideas

Every space, every object, every piece of architecture ever built was an inspired creation of an architect or designer. Some good, some great, some pure genius.

So, what will you create next?

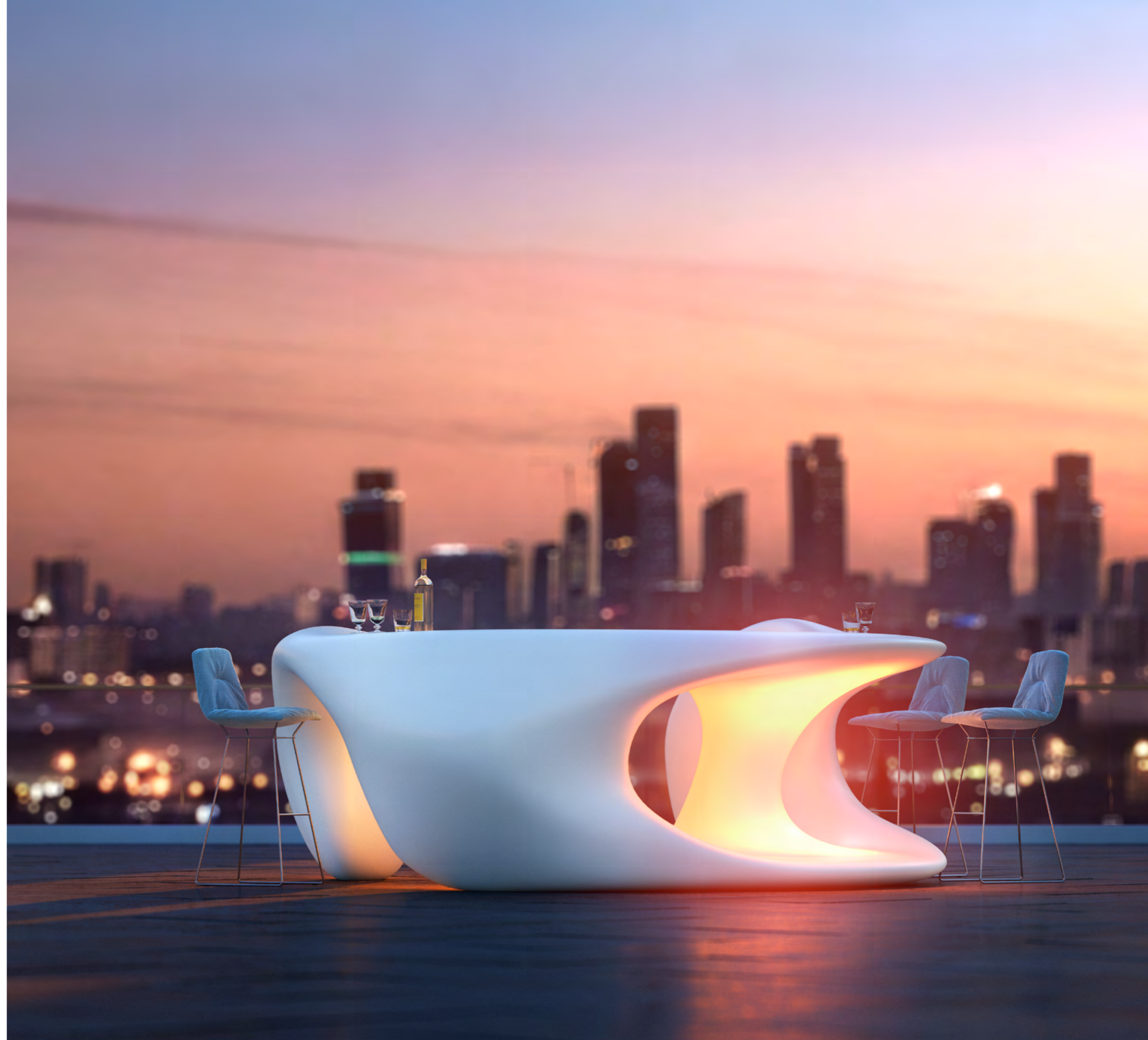

Off outside

If you have worked with HIMACS materials before, you will know the effect: your own ideas and the creative material inspire each other producing even more outstanding ideas. HIMACS can give shape and form to virtually any of your design ideas. And now, you can use HIMACS outside. With its limitless possibilities and exceptional quality, its the perfect façade material.

Highly functional and exceedingly beautiful facades have been designed since HIMACS S728 Alpine White, combined with KEIL inserts and a BWM structure, successfully passed all relevant ETA.



Design: PAD Architectes for BERT 21 | Fabrication: LCCA | Photo: Mathieu Ducros



Design: Dipl.-Ing. Volker Wiese, Berlin - Kaden Klingbeil Architekten | Fabrication: Kiebitzberg GmbH & Co.KG - Kloefer Surfaces | Photo: Dirk Wilhelmy

Design: by preiswerk, marek.architekten | Engineering: 5D Engineering | Photos: Uwe Roder



Train passengers arriving in Schwäbisch Gmünd are greeted by the bright underpass: the entire wall was designed in Alpine White HIMACS. Made of the Solid Surface Material the curved backlit panels covering the walls of the tunnel in Schwäbisch Gmünd station guide visitors to the exit. The exceptional quality of HIMACS means it was the perfect material for this project.



HIMACS offers clear advantages, especially when compared with other mineral materials:

Outdoor applications

The HIMACS-FR-quality has been tailor-made for outdoor applications and its resistance to UV radiation surpasses that of any other solid surface.

Fire rating test

The HIMACS-FR-quality passed the fire rating test with far better results than any of the other solid surfaces: The achieved SBI test according to EN-13501-1 is the impressive proof of this.

HIMACS facade colour range

The other 11 colours of the outdoor range, too, achieved good results in terms of fire rating. Their excellent results: B1, which allows application in almost every relevant area.

HIMACS is ETA certified

Fixed with KEIL inserts and a BWM structure, HIMACS façade in S728 – Alpine White successfully passed the ETA (European Technical Agreement) tests.



The HIMACS panels are fixed to a clamp using undercut anchors and are then suspended from an aluminium substructure. Horizontal and vertical joints equalise temperature fluctuations and guarantee the necessary rear ventilation of the wall.

Design: preiswerk marek architekten | Engineering: 5D Engineering | Photo: Uwe Roder

It is in the outdoor applications in particular where HIMACS scores with its outstanding properties:

Easy thermoforming

Organic-curved, three-dimensional façade architecture thanks to the thermal moulding capacity of the material.

Translucent qualities

Spectacular light and surface effects are achieved by milling and backlighting.

Advantageous outdoor properties

The HIMACS façade colour range withstands humidity, UV radiation or variations in temperature thanks to homogeneous, non-porous material and other advantageous properties.

A durable material

Easy to clean and maintain, the perfect function and visual effect will last for many years (even damage caused by graffiti can be removed without any trace).



Design: preiswerk marek architekten | Engineering: 5D Engineering | Photo: Uwe Roder

This material offers the ideal solution: its smooth, nonporous finish provides complete resistance in the event of acts of vandalism.

The house that plays with light

HIMACS has a sensuous way of dealing with light: When used as a facade the material provides great aesthetic properties. The light is absorbed or reflected, depending upon the intensity and angle of incidence, and gives the Sokcho Housing in Alpine White a mystical feel.



At first glance, the silhouette of this house appears to be simple. However it posed a challenge to architects and finishers: the interlocking cubes, some with seamless surfaces, some with distinctive dividing lines, are all made of HIMACS.

Design: Woo-jin, LIM AEV Architectures, aev-architectures.com | Photos: AEV Architectures



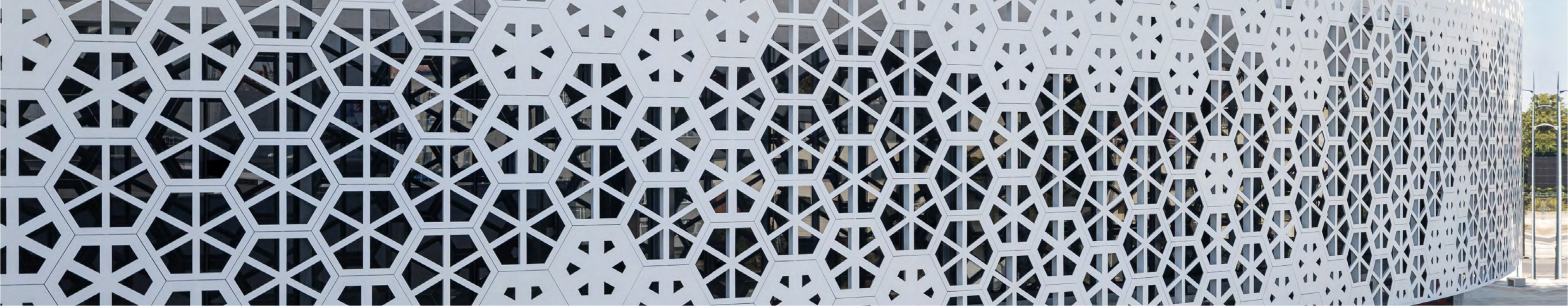

The stars shine bright outside

This wonderful facade of a sport hall complex is an impressive 2,100 m². HIMACS was chosen because of its aesthetic – and its certified fire resistance. HIMACS successfully underwent numerous fire resistance tests, and has received the NRO (Non Spreading Fire) certificate from the Polish Fire Test Facility (ITB), making it one of only a very few solid surface materials to be approved in Poland for use in outdoor facades.

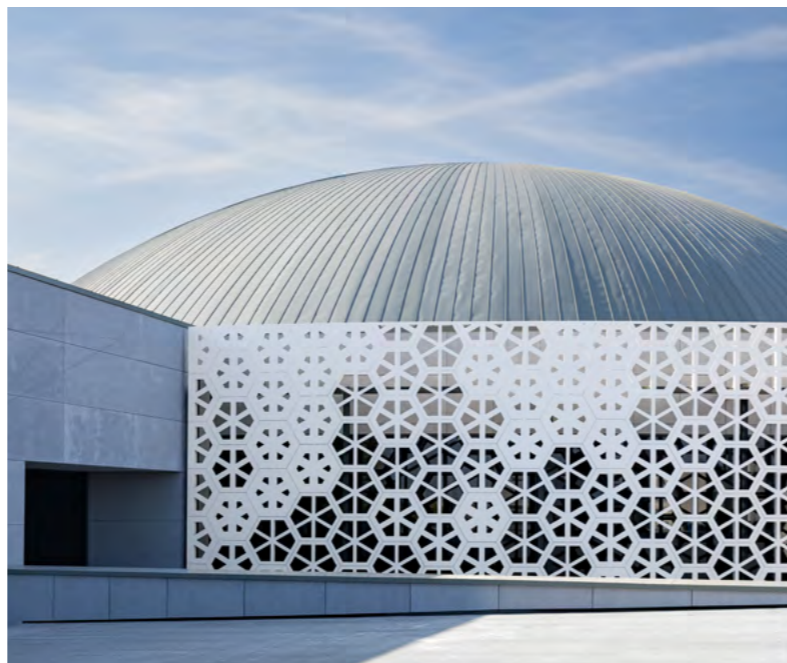

Design: Dorota Szymaniak - Urban | Fabrication: Studio Reklamny Euromet |
Photographer: Cati Graz, Hubert de Jakusz-Gostomski



Modern CNC milling technology allowed all facade elements to be individually designed; the expansion joint – a required part of the facade – is transformed into a cool design element.

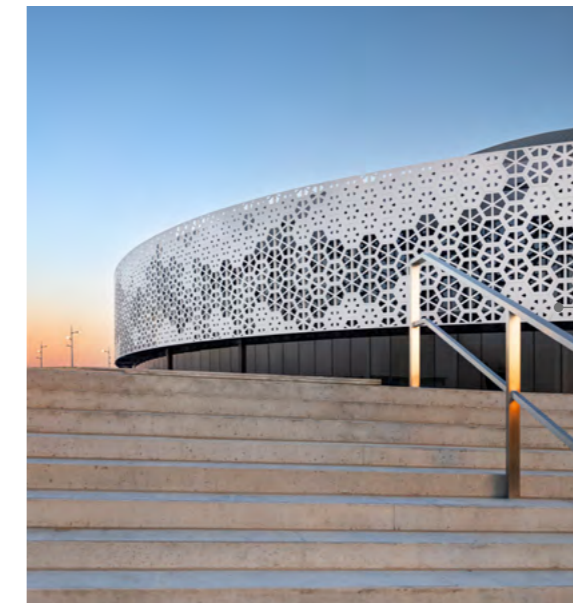

The geometric honeycomb pattern gives the building a sense of transparency and stability all at once.

When the facade tells a story

The façade of the Bieblova residence project, built using HIMACS Solid Surface, has been designed by P6PA+Architects as a tribute to Konstantin Biebl, a prominent Czech poet from the inter-war period who lends his name to the street in Prague where the building is located.



Precise milling, effective back-lighting, near-invisible installation equipment and the robustness of an inner-city facade: HIMACS offers all this.

Design: P6PA+Architects, s.r.o., p6pa.cz, Martin Klejna, Javier Navas Fabregat | Fabrication: Duolit s.r.o., Atlas Group s.r.o., Dřevovýroba Podzimek s.r.o. | Photo: Miguel Alonso





Design: Pierre Guidoni, Jean Rogliano | Fabrication: Menuiserie Bareau, France | HIMACS Supplier: Mobistrat, France | Photos: Mathieu Ducros

Formed by a sea breeze

This ultra-modern villa on the French Riviera conjures images of a super yacht: With its striking railing, different-sized portholes made of HIMACS and especially the sinuous wind- and weather-resistant facade made of the same high-tech material, this impressive building perfectly reflects its maritime location above Cannes.

Our HIMACS material dominates inside as well as out. The outstanding thermoforming qualities which are vital to architects and designers work inside, while the resistance to wind, weather, UV radiation make HIMACS the perfect outdoor material.



Making a grand entrance

The roof sculpture appears to float above the entrance. In reality, the striking roof and wall construction was seamlessly assembled from over 100 large-scale HIMACS plates. Coupled with its timber and steel substructure, this produces an aesthetic and yet stable masterpiece.



Design: Querkopf Architekten GmbH, Wasfy Taha, Fionn Mögel, Germany, querkopf-architekten.de | Fabrication: Likoo / Betriebsgesellschaft GmbH, Germany, likoo.de | Photo: Dominik Reipka Fotograf



The entrance foyer opens to the outside through the large windows. Inside, the ceiling that lets light flood in coupled with the reception desks, both made of HIMACS, provide a link to the exterior made of the same material.

HIMACS transforms from day into night

This impressive gate can be seen at a busy road in the heart of Berlin. The exterior of the gate is entirely clad with HIMACS material. The material is carried on all the way to the interior and is produced in a stylish white throughout.

While the robust and effectively staged surface dominates the facade outside, it is the many small fabrication details inside which offer the arguments in favour of HIMACS: both the address and a clear pattern of dots create an impressive effect. Thanks to our exclusive Thermalcure technology, HIMACS can be effectively machined, and milled.

But the special highlight can only be seen at night: the entire gate is fitted with an LED technology which is invisible during the day. Graphic patterns or letters can be projected on the HIMACS surface, turning the straight installation into a dynamic stage for lighting design.



During the day, the lighting technology is invisibly hidden and protected by the robust HIMACS surface.



Customers of this office complex are enthusiastic about the animated snowflakes visible on its façade.



Effectively animated outside, inside a clear design of dots and letters milled out by using the CNC technology.

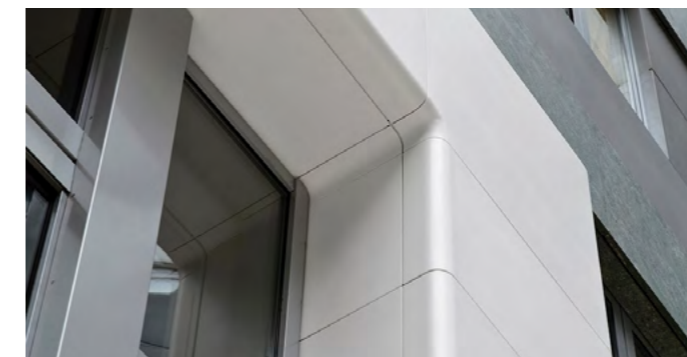

One of the most important features when using HIMACS on a facade is its ability to create round corners.

Non-standard facade. Unlimited design.

ETA certified, thermoformable, polyvalent, ultraresistant, and non-porous, HIMACS new generation acrylic stone has enabled the construction of a non-standard facade that, in all respects, complies with the requirements of the world leader in sailing-boat construction.

In addition to the aesthetic effect with a motif that is inspired by fishing nets, reproducing the Bénéteau logo and recreating a wave, the perforation of the material, which is over 50%, provides the required level of transparency whilst regulating heat from radiation.



Design: PAD Architectes for BERRI 21 | Fabrication: LCCA | Photo: Mathieu Ducros



Shaping the future. In harmony with the environment.

Countless internationally recognized certificates attest that HIMACS has a strong focus on ecological aspects. Without exception, all HIMACS products are manufactured in accordance with the ISO 14001 environmental standard.



When you approach the beautiful linear building, you simply can't believe that it was the material's ecological and sustainable aspects that first and foremost advocated the use of HIMACS. Apart from its sensational aesthetic qualities, it was also its impressive feel that was crucial when it came to making a decision.

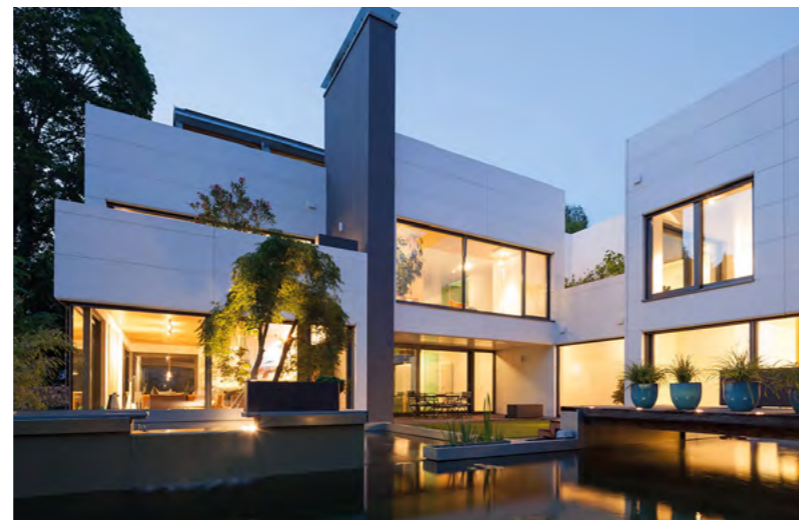

Design: Dipl.-Ing. Volker Wiese, Berlin - Kaden Klingbell Architekten | Fabrication: Klebitzberg GmbH & Co. KG - Klopfer Surfaces | Photo: Dirk Wilhelmy



Architect and builder Volker Wiese has realised his personal home design dream with a Bauhaus style residence with exterior HIMACS cladding that secures privacy from the outside but encloses a delightful

garden with-in a multi-façade, two wing design. For the keen nature lover that Wiese is, using acrylic stone for the exterior wall cladding was an obvious choice as all the materials used in this energy efficient structure are sustainable.

HIMACS is adaptable to all styles

Integrating a new contemporary building in a historic ensemble calls for tried and tested expertise in project management. Accordingly, the architect Florian Köhler imitates the plan of the façades constructed with plaster mouldings on the old buildings in the Ottensen district in Hamburg, and applies it to his new project using HIMACS panels.



To echo the smooth, dazzling white surfaces of the historical buildings, the architects chose brilliant white light reflecting panels made of "Alpine White" HIMACS, giving the dynamic shapes of the surface a certain depth effect.



Design: Köhler Architekten | Fabrication: Peter Knapp Dach und Fassadentechnik GmbH, Abalit Elementos Moldedados, Peter Grube | Photo: Nikolaus Herrmann

Maximum versatility for creative design

This modern building houses the oil company NAM (Nederlandse Aardolie Maatschappij) in Assen, Netherlands. The reception area is almost entirely built in HIMACS, starting with the exterior façade decorated with a backlit sign representing the company's logo.



The architectural firm Kwint Architecten designed a reception room which receives visitors in a continuous flow between the outside and the inside, using a HIMACS wall which links the two areas and eventually leads to the reception desk. The interior partition is finished and backlit to create a bas-relief which echoes the identify of the brand. Its a great result, when architect and client join together to make such a quality building.



Design: Kwint architecten | Fabrication: Bouwborg -Harryvan b.v. | Photo: Gerard van Beck.



The use of the HIMACS material for the window frames, the walls and the furniture helps to create a homogeneous and refined unit which has enabled a new area to be integrated into existing architecture without creating conflict.

Convincing inside.

Inside public buildings.

The requirements for public spaces are very demanding. HIMACS regularly undergoes all the necessary material tests and has all the requisite certificates to meet these exacting quality requirements. The use of HIMACS, the Solid Surface Material by LX Hausys, in this swimming pool in the heart of Paris's 19th district has achieved a superb finish.

This innovative project proves once again the diversity and exceptional quality of this solid surface material: the optimum dimensional tolerance of HIMACS was extremely important for achieving a perfectly worked result in this challenging swimming pool project with its large flush-mounted wall panels.



Design: Yonseux Architectes | Fabrication: ASKA Interior | Photo: Alexandra Mocanu

Convincing outside.

All of a sudden a building has haptic qualities.

These white elements create a uniform impression: all window framings and some wall elements are made from HIMACS, increasing the value of the building considerably. Especially the bottom section of the façade which is within reach of passers-by: wonderful if spectators "look with their hands" being able to feel the perfect touch of the material.



Design: SchröderArchitekten | Fabrication: Kiebitzberg Möbelwerkstätten – Klöpfer Surfaces | Photo: Dipl. Ing. Arch. F. Aussieker



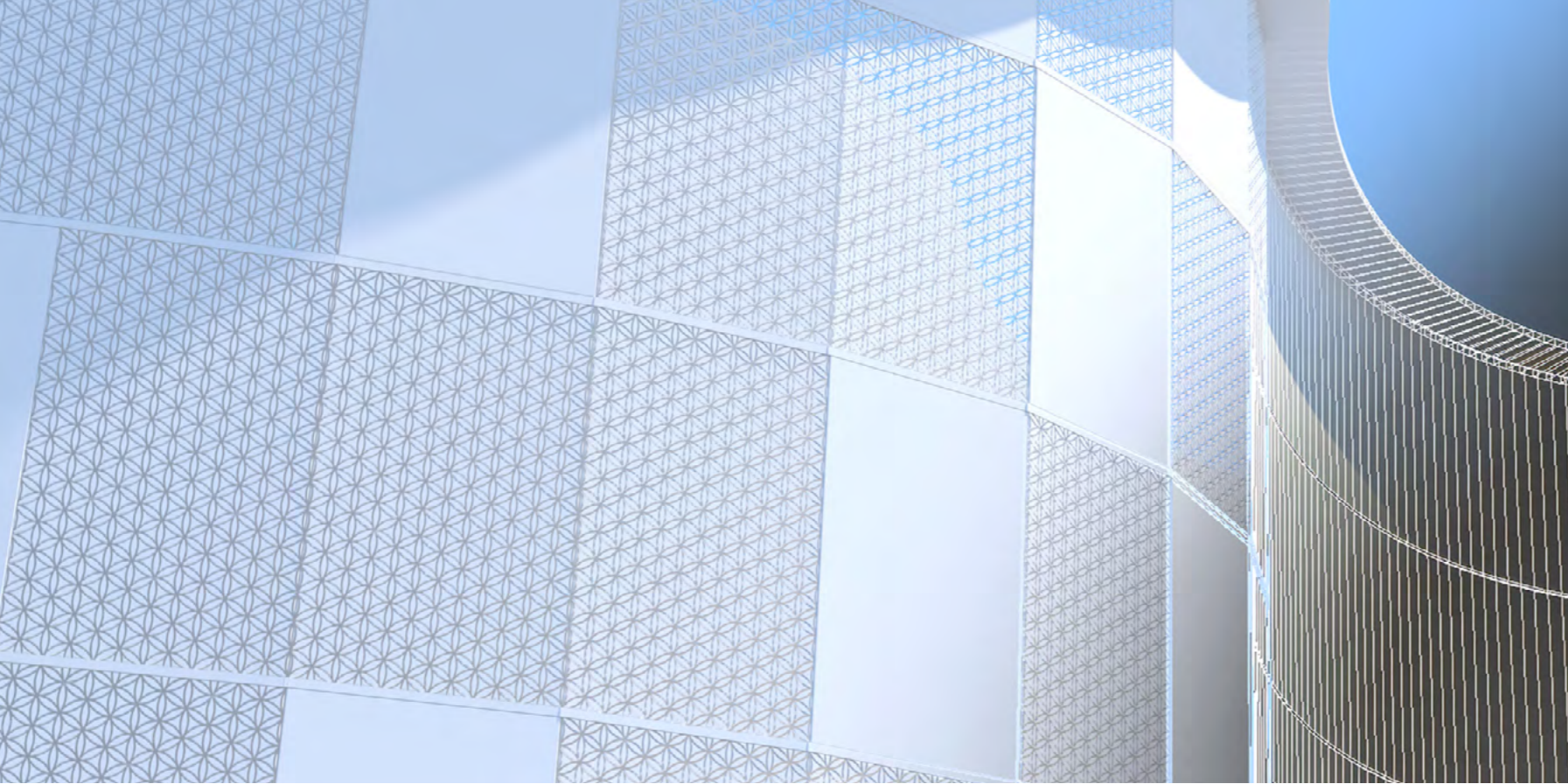

- **HIMACS-FR - Minimal flammability:** S728 (Alpine White) is the FR formulation, which for many years, has offered increased fire resistance – certified by the ETA.
- **HIMACS-UV+ :** S828 (Alpine White) is the new exterior formulation offering better UV resistance, which is particularly important when the façade is exposed to high levels of sunlight.
- All colours labelled with a sun symbol can also be used outdoors.

With HIMACS Exteria® it's now even more fun to be on the move outside.

For years, spectacular façades have been made from HIMACS all over the world. In doing so, the advantages are often skilfully crafted: Relief milling with writing, samples with company logos, combined with spectacular light effects and curvy designs. And every good design inspires the next big thing. Together, we can now take the next steps. With HIMACS Exteria®, LX Hausys is expanding exterior possibilities.



Design: Woo-jin, LIM AEV Architectures | Photo: AEV Architectures

Choose the outdoor expert

In Europe, for good reasons, there are strict regulations regarding material behaviour, especially the fire performance. This applies to many areas within a building, as well as to its façade, rendering a lot of materials unsuitable for use in safety relevant areas.

The HIMACS Outdoor Range offers a choice of attractive shades and, above all, maximum safety for the planner, the fabricator and the builder – last but not least for the occupants of the building.

HIMACS façade colour range achieved for example the B-s1-d0 classification of SBI (Single Burning Item) according to the norm EN ISO 13501 as well as the German B1 classification according to the norm DIN 4102-1; and the M1 classification according to the French norm NF P92-501.

Warranty

HIMACS offers a 10-year warranty on the UV resistance of the exterior colours. The loss of shine is less than 40% with matt finishes. A 10-year warranty that the colour does not leach and 20-year warranty that the material does not flake off, swell or become delaminated is also offered. The warranty period starts from the installation date and only applies to the sheet material. Adhesives are excluded from the warranty. The warranty conditions are based on practical experience and tests are continuously performed in independent laboratories. For more information visit [lxhausys.com/en](https://www.lxhausys.com/en).

Great UV resistance.

This is where the quality of the HIMACS material comes into its own. Some colours are rated with the UV classification Delta E2, E5 and other colours are rated Delta E15 during 10 years.

HIMACS Exteria®

Click here and discover our complete colour range on [lxhausys.com/eu](https://www.lxhausys.com/eu)

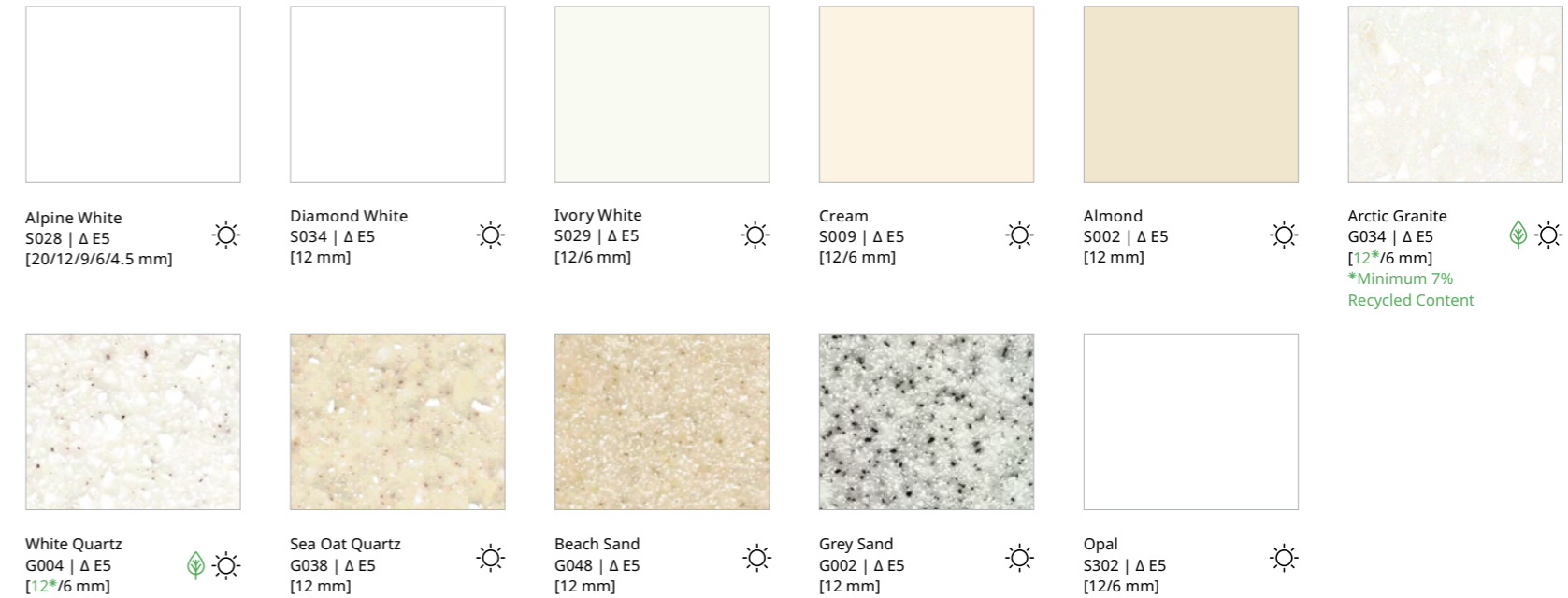

Our applications engineers suggest 12 mm strong HIMACS sheets for façade construction. To discover the most up-to-date colour offering for outdoor applications, visit our website [lxhausys.com/eu](https://www.lxhausys.com/eu).

HIMACS Alpine White for special requirements

HIMACS-FR – Minimal flammability

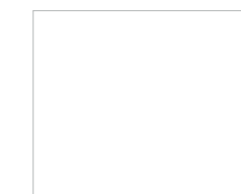

Alpine White
S728 | Δ E5
[12 mm]

The individual material FR quality resulted in fire protection classification "B-s1-d0" according to EN 13501 (Single Burning Item test (SBI test)). Fixed in place with KEIL anchors and a BWM construction, the HIMACS façade in FR S728 CE MED Alpine White successfully passed the ETA tests (European Technical Agreement).

HIMACS UV+ – Improved UV resistance

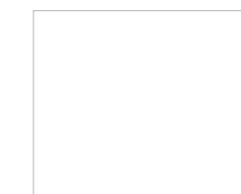

Alpine White
S828 | Δ E2
[12 mm]

HIMACS Ultra-Thermoforming

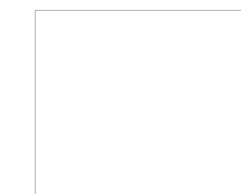

Alpine White
S928 [12* mm]
*Minimum 8% Recycled Content

- Contains SCS certified pre-consumer recycled content.
- SCS certified pre-consumer recycled content only applicable to the indicated thickness.

Great Quality Material means great resistance to the outdoors

Technical Properties

SPECIFICATION		RESULT	UNIT	TEST METHODS
Flexural E-modulus	Ef	8900	MPa	DIN EN ISO 178
Flexural strength	σ_{fm}	76,9	MPa	DIN EN ISO 178
Breaking elongation	ϵ_{fm}	1,01	%	DIN EN ISO 178
Electrostatic Conductivity		> 1 x 10 ¹²	Ω	EN61340-5-1 DIN IEC 61340-4-1
Diffusion resistance coefficient	μ	1807		DIN EN ISO 12572
Density		1,71	g/cm ³	ISO 1183
Heat conductance	λ_{10tr}	0,636	W/mK	DIN EN 12664
Resistance to thermal expansion	R	0,048	m ² K/W	DIN EN 12664
Thermal expansion coefficient	α	0,048	mm/mK	prEN 14581
Linear expansion coefficient		max. 48 x 10 ⁻⁶	m/°C	
Tensile resistance	σ_{fm}	32,7	MPa	DIN EN 527
Water absorption		< 0,1	%	DIN EN 438 – part 12
SBI fire performance		B - s1 - d0		DIN 13501

*applicable to HIMACS FR S728 Alpine White, tested with subconstruction and insulation

Fire performance

PRODUCT CONCERNED	TEST METHOD	RESULTS
HIMACS FR - 12mm	DIN EN 13501-1, SBI	B-s1-d0
HIMACS FR - 12mm	NF P92-501:1995	M1
HIMACS FR - 12mm	DIN 4102-1 EN 13501-1	B1 B-s1-d0

HIMACS Exteria® Certificates



Fixed with KEIL inserts and a BWM structure, HIMACS façade in S728 – Alpine White successfully passed the ETA tests (European Technical Agreement).

The appropriate technology: HIMACS as a ventilated rainscreen facade

A cross-section of the rear-ventilated facade.

If you would like to benefit from the wonderful design possibilities and functional advantages offered by HIMACS and use it as façade material, we suggest planning a ventilated rainscreen façade. This very common system separates the thermal-insulation and weather-protection functions.

Here HIMACS benefits from its special mix of significant properties which render the material virtually predestined for outdoor application. The certain dimensional tolerance of HIMACS is an attractive feature for the material.

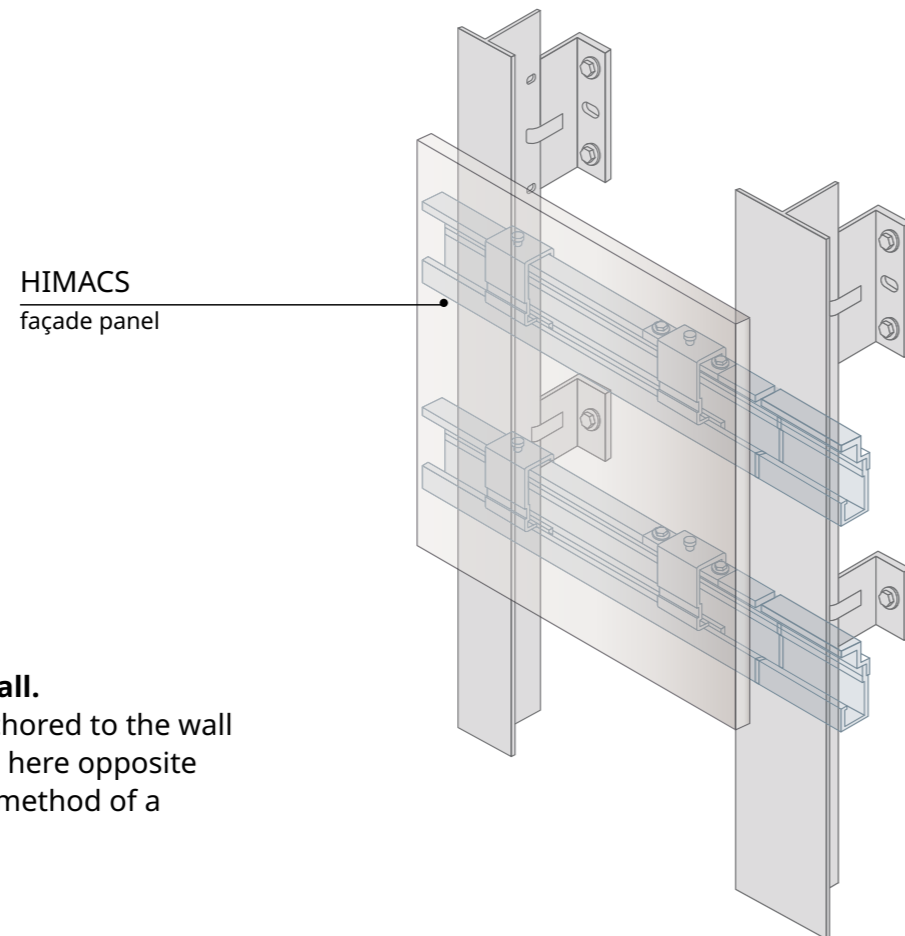

The subconstruction on the wall.

Through the way panels are anchored to the wall professionally, the cross-section here opposite demonstrates the construction method of a ventilated rainscreen.

Simple flashing details.

HIMACS and the recommended subconstruction also allow the installation of roof and wall flashings or windowsills – easily and without any problems, just like the entire façade.

Attic flashing (upper flashing)

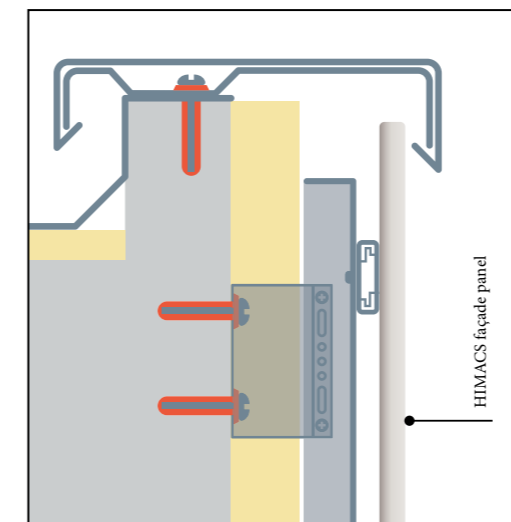

Windowsill

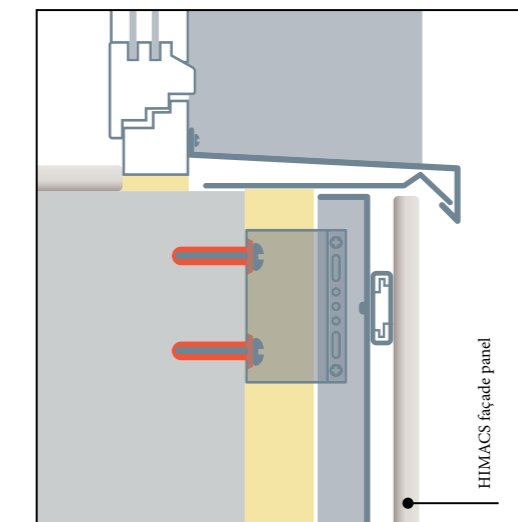

Base flashing (lower flashing)

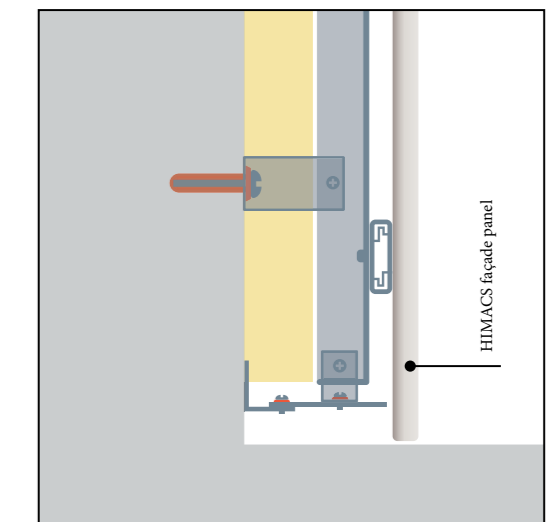

Perfect protection against all external influences. Thanks to the ventilated façade – and HIMACS.

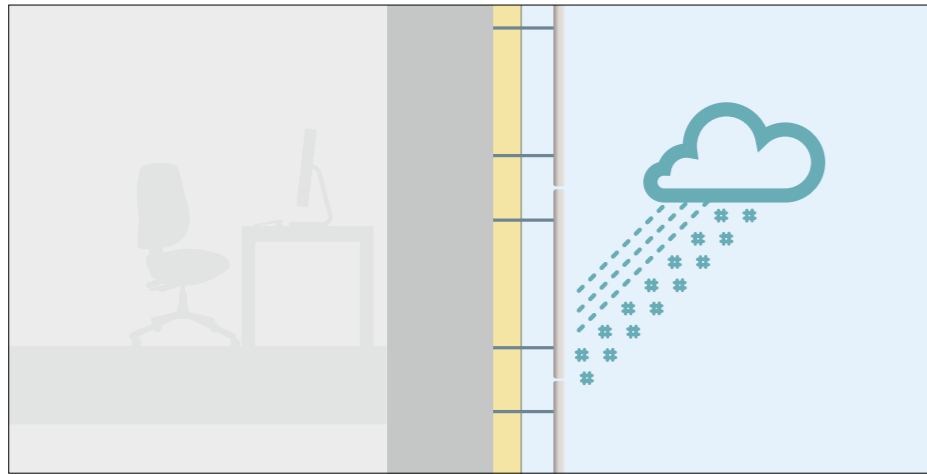

Perfect moisture resistance

HIMACS is highly resistant to moisture like rain, snow or condensation, thus providing excellent protection for the insulation layer behind the façade. Furthermore, any moisture is perfectly removed via a gap between the façade panel and the insulation material.

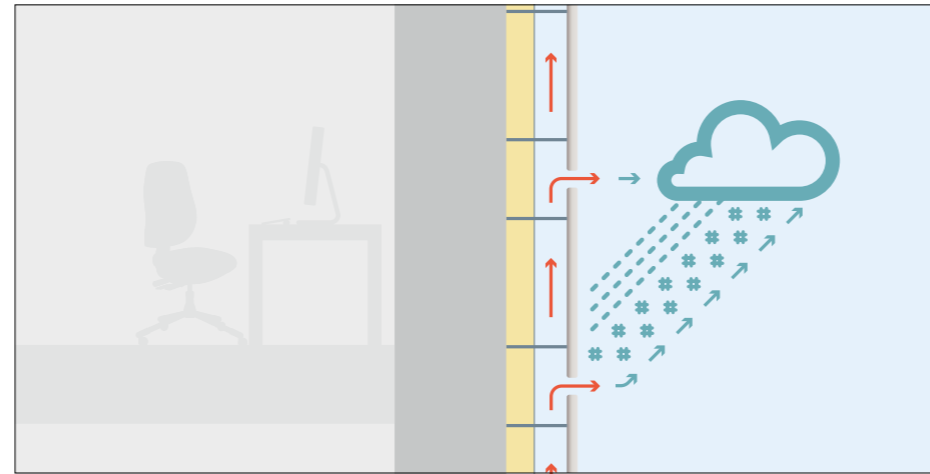

Perfect air circulation

In connection with the ventilated rainscreen technology, HIMACS ensures air circulation irrespective of low or high temperatures. This method removes condensation moisture and prevents damage to the insulation layer.

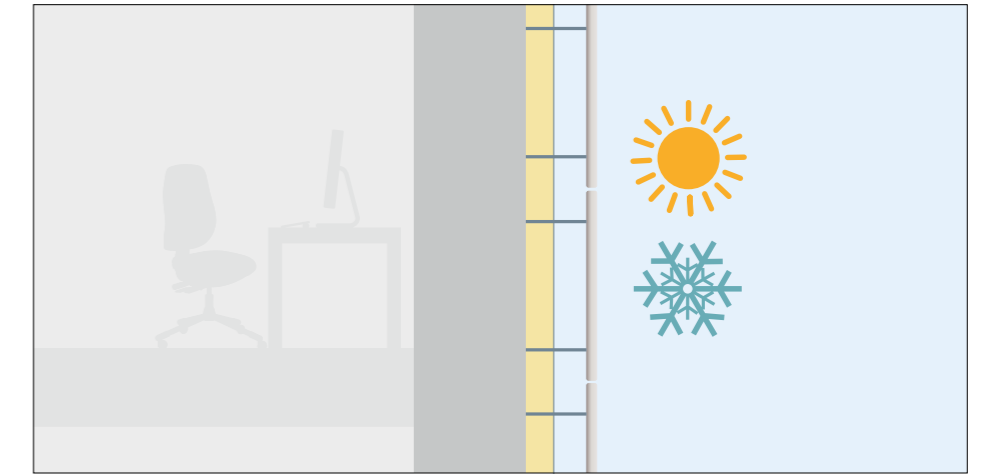

Perfect insulation properties

HIMACS withstands cold and heat equally. These insulation properties result in significant energy savings.



Perfect noise insulation

HIMACS façade materials provide optimal noise insulation thus reducing the noise level significantly.

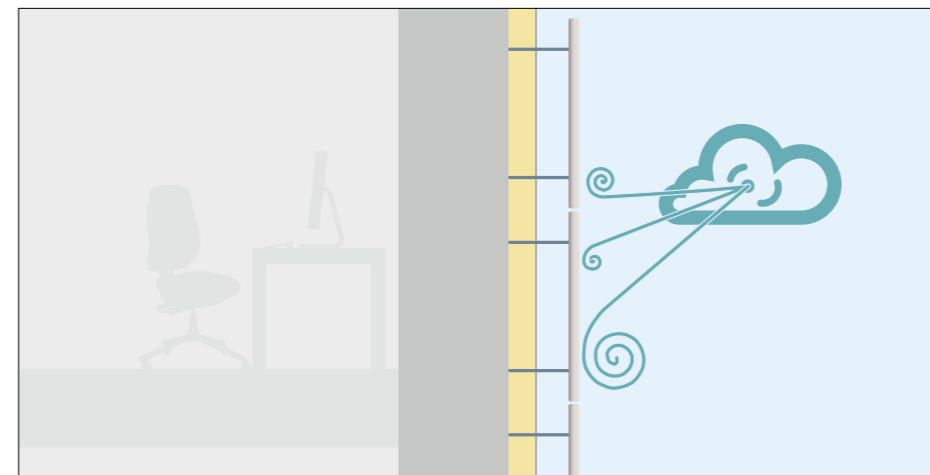

Perfect resistance to wind pressure

HIMACS façade materials attest bending strength above average thus offering excellent resistance to wind pressure.

The optimal method of mounting HIMACS on walls

Adjustable aluminium subconstructions are used for the professional mounting of HIMACS façade elements. LX Hausys suggests using proven highquality products such as those offered by BWM installation system.

These elements are used to anchor HIMACS slabs on walls leaving a 20 mm gap between the slabs and the insulation material: a perfect space for the vital air circulation. The insulation layer itself is well kept in place between the

aluminium sections and the wall. Depending on the state of the building, the subconstruction is aligned to the individual requirements determined by the architect.

HIMACS panels are mounted – invisibly from the outside – to the aluminium substructure. We recommend using an invisible undercut anchor which is offered by KEIL attachment technology.

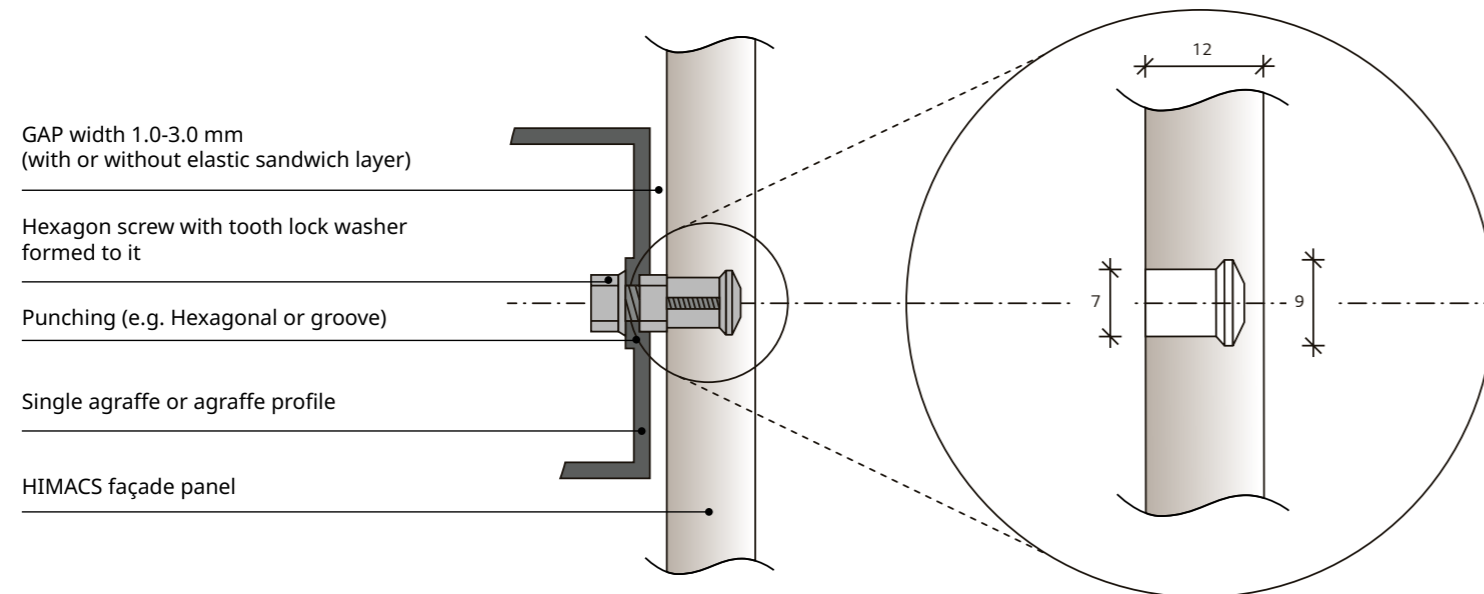
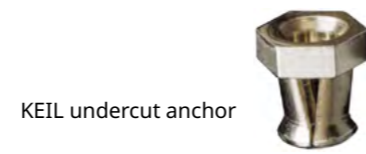

How to join the panels

There are different ways of joining two HIMACS panels within the ventilated rainscreen. The methods shown here allow for expansion joints of at least 8 to 10 mm.

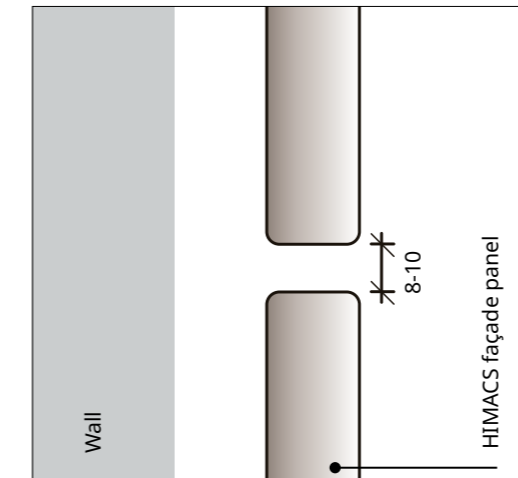

Open joint
without sealing on the reverse side

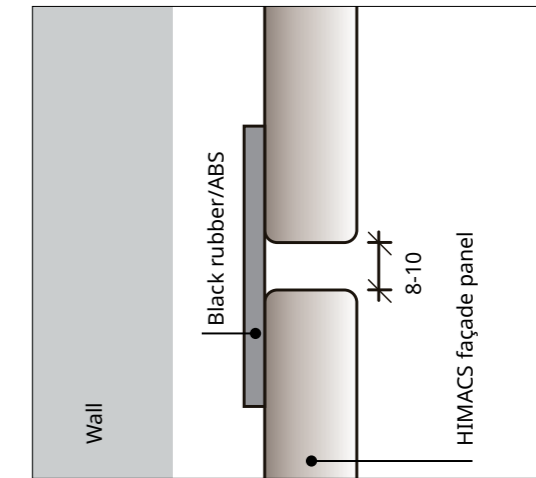

Open joint
with sealing on the reverse side
(rubber or ABS plastic)

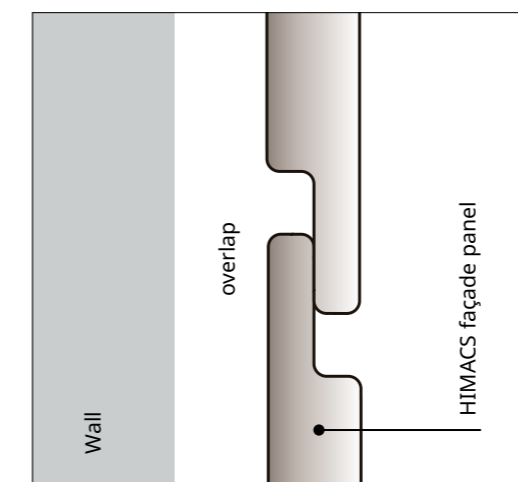

Overlapping panels

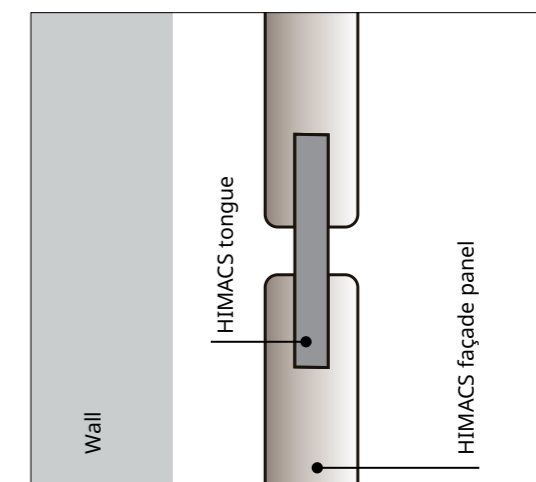

Tongue and groove joints
(tongue element made from HIMACS)

Please feel free to contact us for further information

HIMACS. The shape of your ideas

European Headquarters:
LX Hausys Europe GmbH
Lyoner Str. 15
60528 Frankfurt am Main
Germany
himacseu@lxhausys.com

To find the contact for your region,
please visit our website.

lxhausys.com/eu



HIMACS is a registered trademark of LX Hausys. All other trademarks and product names are trademarks or registered trademarks of their respective rights owners. The information contained in this brochure is intended to be for information only and can be amended at any time without prior notification. ©2024. LX Hausys Europe GmbH. All rights reserved.